

V-Type Modifications



Thank you for purchasing your new Robinsons greenhouse. We recommend you familiarise yourself with the instructions and read all safety information before you commence assembly. This instruction manual is also available online at www.robinsonsgreenhouses.co.uk in our technical help section should you need to reprint it. Should you require any additional advice you can always call us on 01782 385409.

These instructions are to be used in conjunction with the main instruction manual/s (read them all before construction begins).

Safety Warning

- Glass and aluminium can potentially cause injury. Please ensure you wear protective goggles, gloves, headgear and suitable footwear when assembling and glazing the building.
- Please remember that glass is fragile and should be handled with extreme care. Always clear up and dispose of any breakages immediately.
- Do not assemble the greenhouse in high winds.
- For safety reasons and ease of assembly, we recommend that this greenhouse is assembled by a minimum of two people.
- Please clear all lying snow from the greenhouse roof as it can cause the roof to buckle or collapse.

Site Preparation







- When selecting a site for your greenhouse, it is vital that you choose as flat and level an area as possible.
- A concrete or slabbed base will provide the most solid foundation for your greenhouse.
- IMPORTANT: Do **not** fix your building down until the building is fully assembled, including glazing.
- Avoid placing your greenhouse under trees or in other vulnerable locations.
- To minimise the risk of wind damage, try to select as sheltered a site as possible, e.g. beside a hedgerow or garden fence.

Additional Considerations

- Please bear in mind that assembling your greenhouse can be time consuming. You may need to spread the construction over two or more days. We recommend that you avoid leaving the building partially glazed. If you ever have to leave your greenhouse half assembled and not anchored down, weigh it down with slabs or bags of sand to stop the wind moving it.
- You will find it helpful to prepare a large, clean and clear area in which to work in. A garage floor or flat lawn area is ideal.
- If you have arranged for someone to install your greenhouse for you, please check that all components are included.
- Anchoring down your greenhouse should be the final stage of construction (including glazing).
- Once installed your greenhouse requires little maintenance, but to maintain the smooth running of your door(s) WD40 or similar can be applied to the door wheels and lower door guides.

Guarantee

- Your new Robinsons greenhouse is guaranteed for 10 years against faulty manufacture of the framework. This does not include glazing, moving parts, accidental damage or wind damage.

KEY SYMBOL	KEY DESCRIPTION
	EXTERNAL VIEW
	INTERNAL VIEW
	THINK
	CORRECT
	TWIST TO LOCK
	CUT TO LENGTH



The Robinsons Valley gutter system allows a side to be removed so the frame can be attached to a wall to create what we call a V-type Lean-to.

IMPORTANT: Before you begin it is essential that your wall and base / brickwork are perpendicular to one another, any deviation from 90 degrees will make assembly very difficult if not impossible.

The two part valley gutter with independent pivoting roof pitch flange allows for 10 degree < 45 degree adjustment meaning a multitude of possibilities can be realised across the entire Robinsons range.



Longer buildings (12'+) will utilise A-frames (see extension manual/s) to add strength to the overall structure and help the valley gutter tie in with the rest of the frame. A-frames occur where two sections adjoin lengthways, they are attached to side and roof bars. Note: your A-frame components will not directly attach to your valley gutter as there are no corresponding side bars to the roof bars on the wall side. Ornate castings 'D1089' should be spaced to correspond with the roof bars and inset from each end, they are used to support the gutter from beneath. Each 'D1089' is anchored to the wall using 2" rawl plugs and screws.

The wide valley gutter channel is designed to be able to easily cope with high rainwater volumes and it can be used to carefully access the valley area of the structure for cleaning and maintenance purposes if required. Take great care when walking in the valley gutter, do NOT stand in the valley gutter until the building is complete and make sure you are not alone. If walking down the valley gutter channel it is advised you run a wooden beam horizontally spanning from ridge to your wall which you can move down the structure with you supporting you as you move. Only one person should access a valley section at any one time (max. weight limit 100Kg) whilst another supervises at ground level. Please do not stand on the valley outlet 'D1082' or the first 200mm of valley gutter which canopies a pane of glass below. On buildings longer than 12' the valley gutter is in more than one length and needs to be very well sealed and joined using the provided extension plates, see page 11 to ensure that the building does not leak, an essential job which should not be rushed. Test all of the gutter joints are watertight with a watering can or a hose if you are working on a dry day. If your building is in an exposed location you may also wish to consider adding some flashing above the valley channel to create a better seal with your brickwork etc..

This booklet is to be used in conjunction with your standard greenhouse and extension manual (if applicable).

General V-type Build guidance:

Section 1: As your greenhouse will be going against a wall one of your sides (if supplied) will be redundant. You only need to build one side therefore not two as stated in the standard manual. The vertical glazing bars, their cap / covers though in that redundant side can be utilised under the valley at the ends. Two are needed at each end.

Sections 2&3: Before you begin building your end gables you need to modify your gable cills by cutting off 43mm from the end nearest the backwall to make two handed / mirrored parts, see right and details on the next page.

On Victorian models an eaves plate (DV104) is used to join the side and roof corners together. The plates nearest the valley need to have some material removed to remove interference with the valley, see details on page 5.

Your standard manual will show each of your end gables as utilising two side corners. With a V-type however the corner nearest your backwall needs to be replaced by one of the unused side bars (rubber both channels) from section 1. An extra 12mm bolt needs to be slid into this bar before it is mounted between the gable cill and roof corner to allow for the valley support angles (D1122 / D1126) to attach.

Two more side bars, caps / covers also need to be modified to fit under the valley to support it and join to the D1122 / D1126's, see detail right and on page 6. These shortened verticals (add rubber to the channel furthest from the wall) will become your wall bars and will need some D234 foam applied to the face nearest the wall to act as a seal / cushion.

In your valley box you will also find two short sections of cill which you need to use to extend the cut ends of your cills towards the back wall. They join using a flat plate D114, see bottom right.

Section 4: You can now join your side and gables together in their final location offset from the wall slightly. You need to preassemble your valley minus the (D1082) end caps, see details on pages 7 and 8. Once assembled the valley can be lowered into place on top of your D1122 / D1126's and the valley flange can be attached to your roof corners at the ends. Once the valley is in place and centralised you can push the frame backwards to meet the wall. You know need to check that your frame is square, your wall bars are vertical and your valley is horizontal. The wall bars and D1089 castings all need to be fixed to the backwall continually checking everything looks level and square. Do NOT anchor the cills down however until the end of the build. Once attached you can insert the end caps D1082 and seal the wall bars and valley whilst it is still easy to access.

Section 5: You can now go back to your main manual and continue construction as normal.

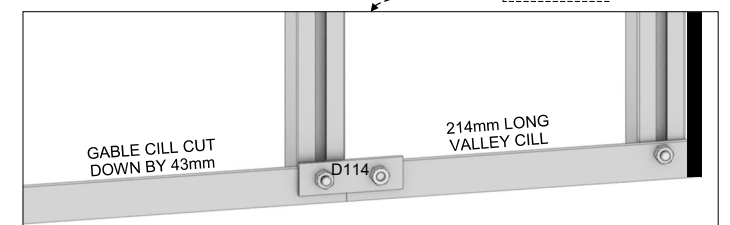
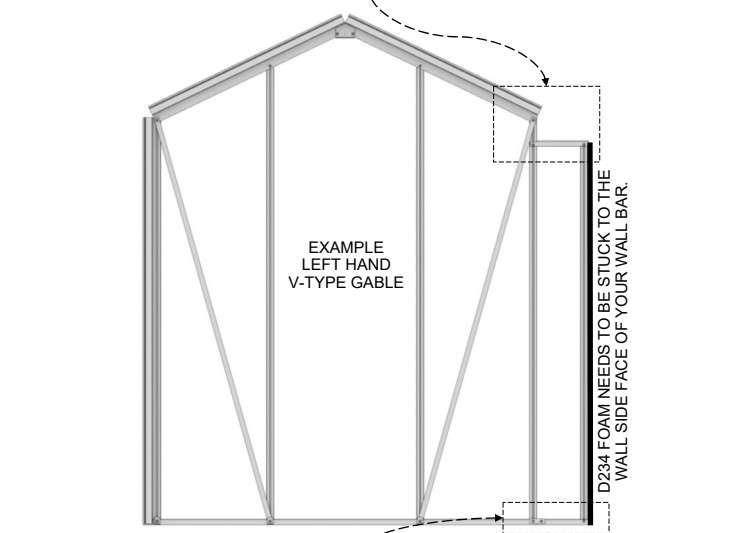
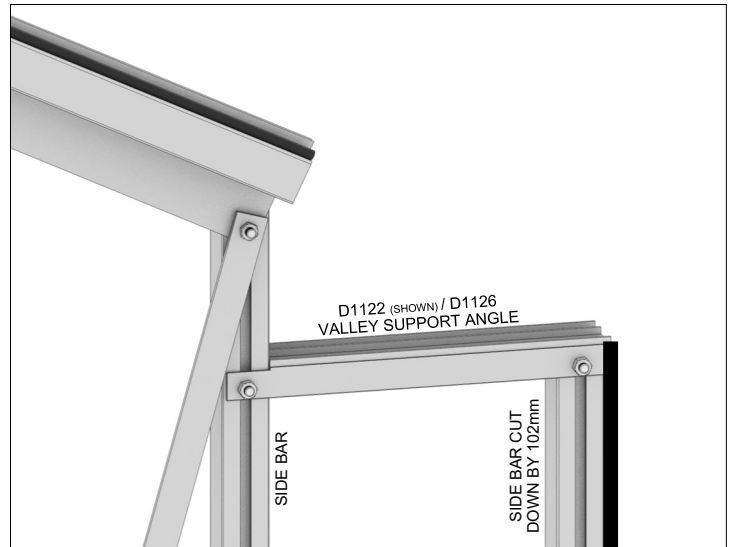

V-type COMPONENT MODIFCATIONS:

Take one of your two identical gable end cills and remove 43mm from one end to make it handed.

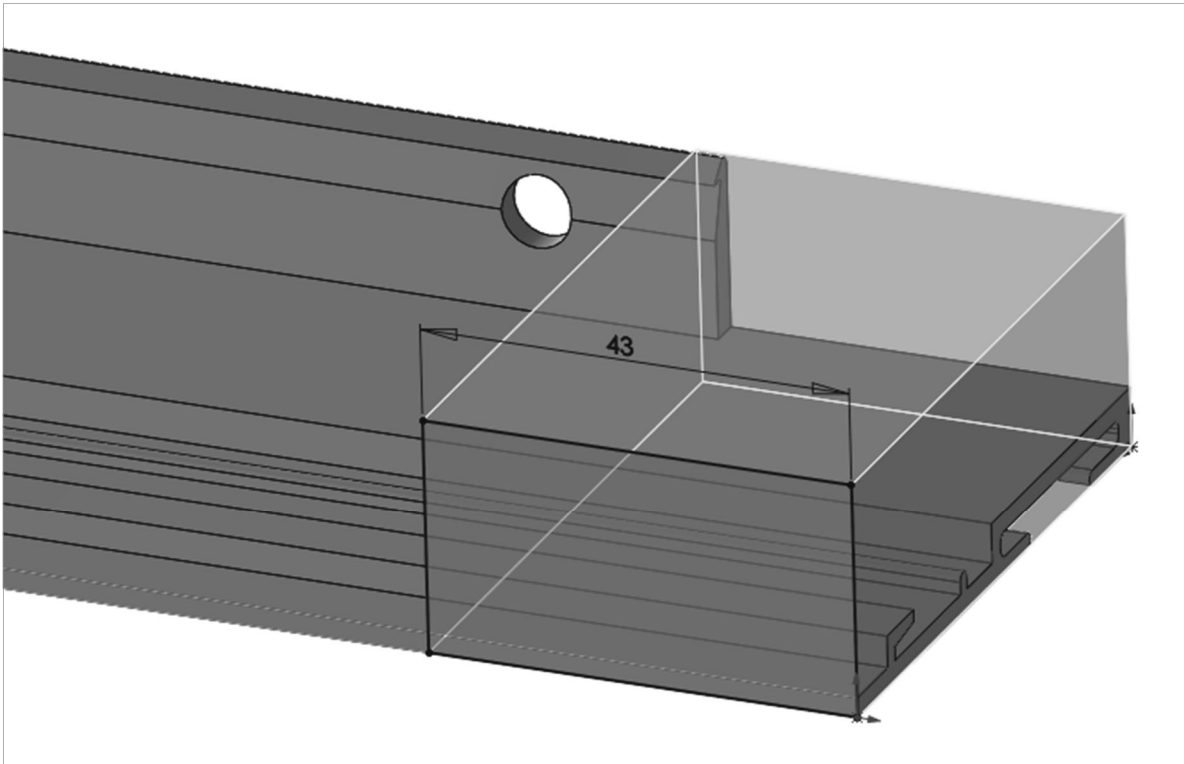

Take the remaining gable end cill and make a mirror image by removing 43mm from the other end to create the opposing hand. If put back to back the two parts should mirror each other and all the holes should line up.

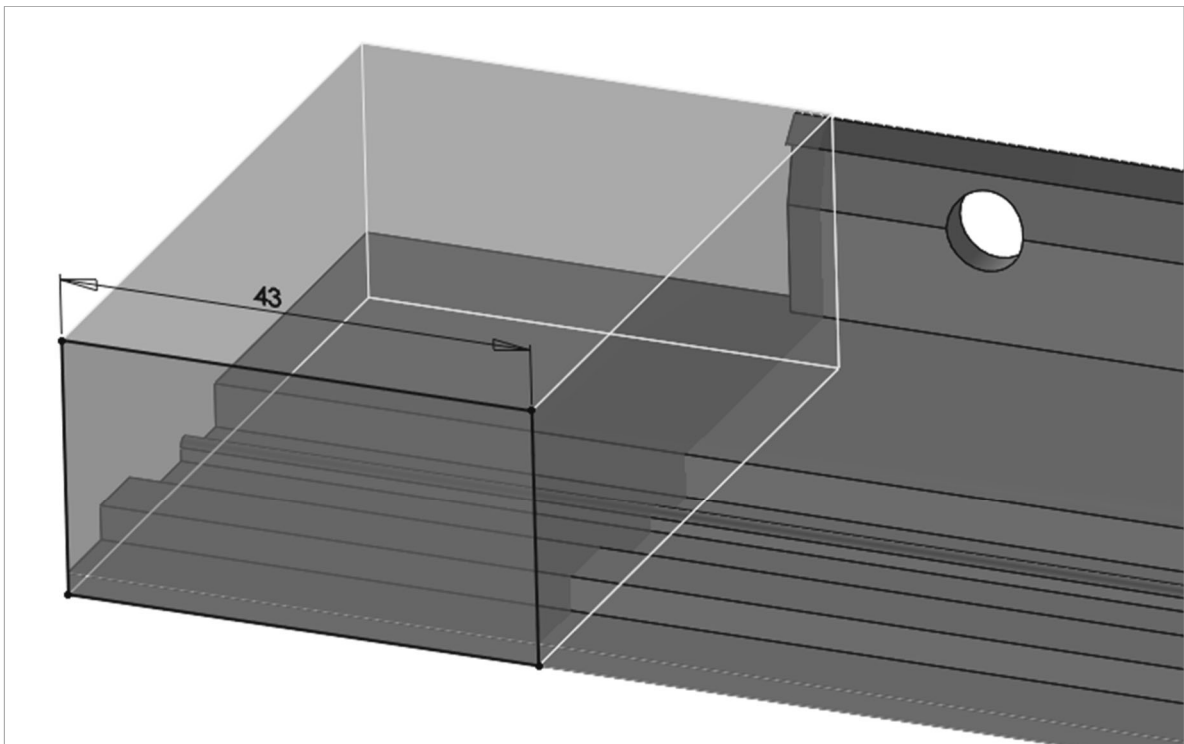



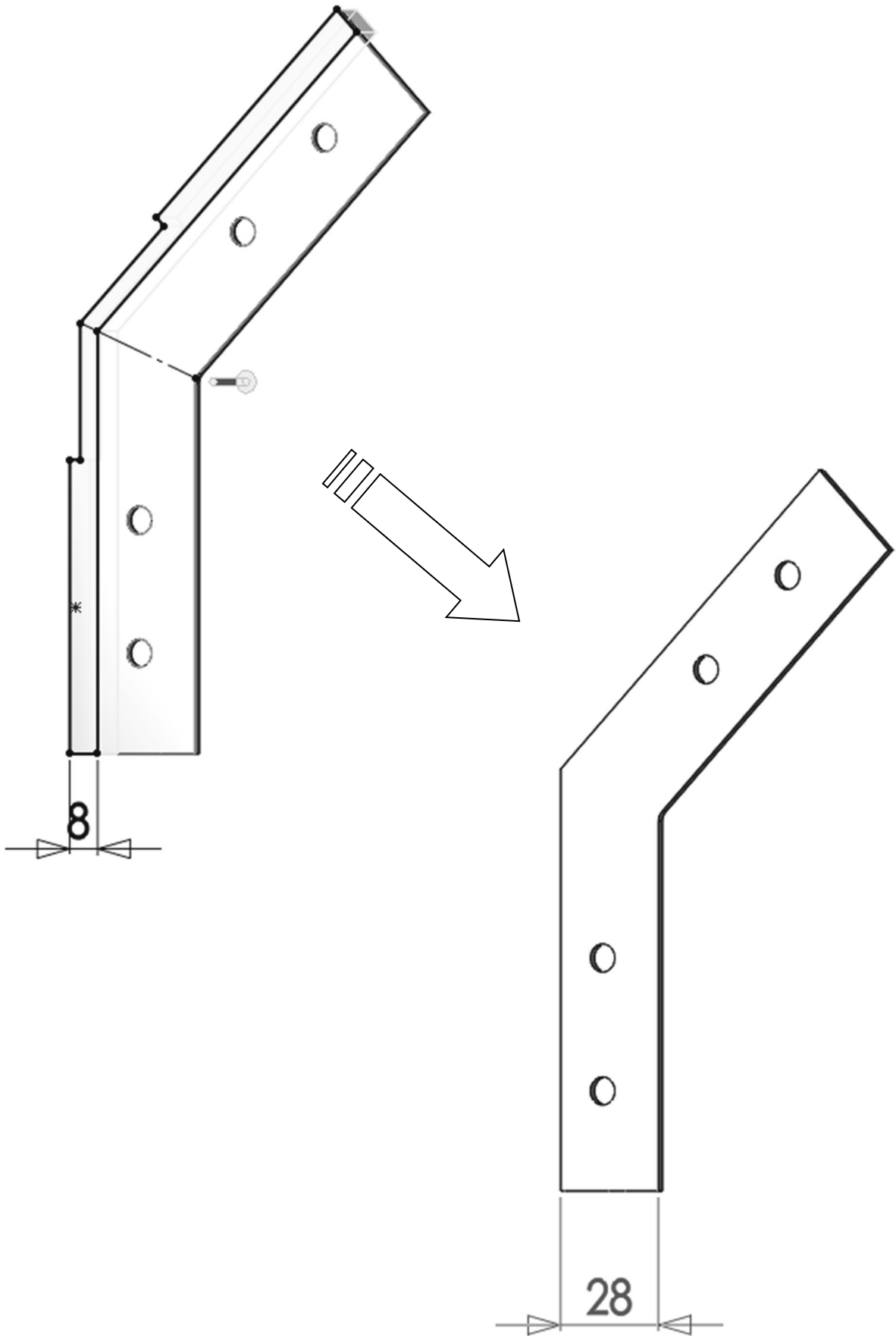

DV104's (x2) need to be trimmed down to avoid interference with the valley gutter. Victorian models only!

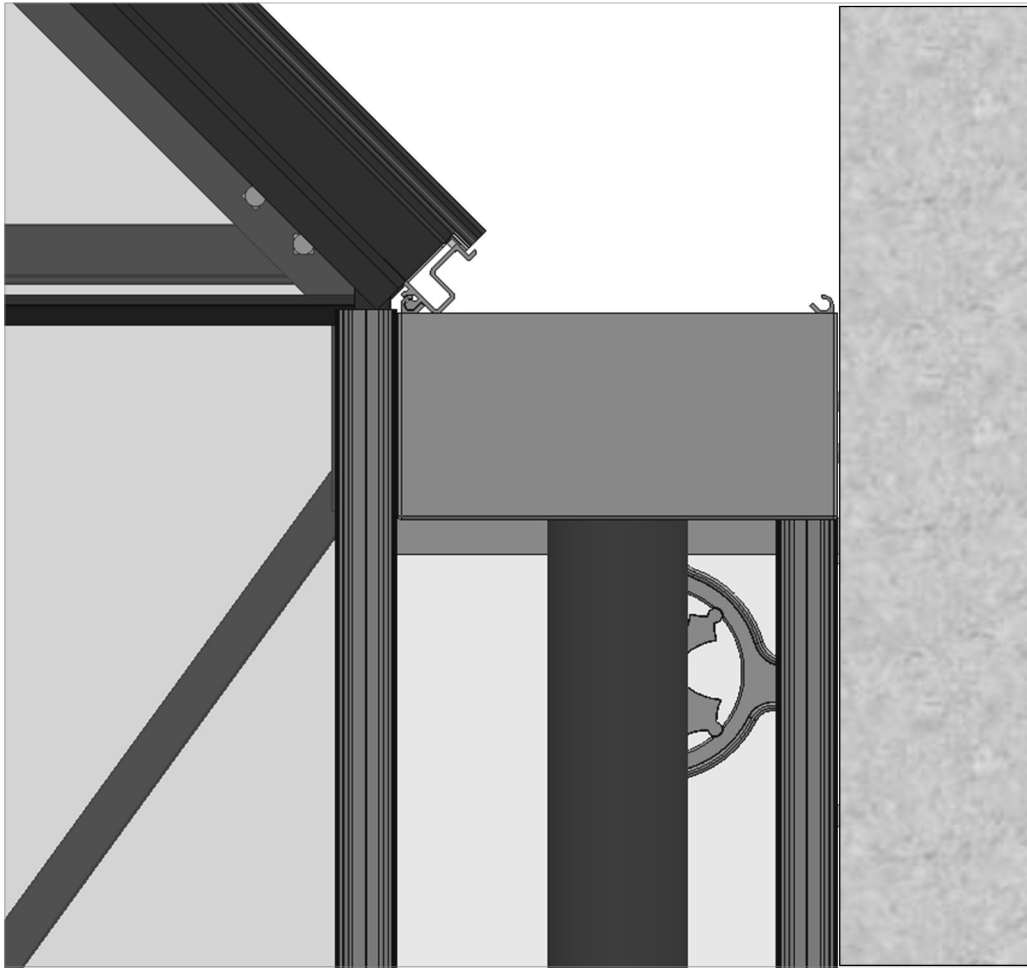





The glazing bars, e.g. D609 (1160mm), their capping e.g. D618 and covers e.g. D619 (each x2) which will go underneath the valley gutter adjacent to the wall at either end of the building need to be reduced in length so that they fit underneath the valley rather than along side it. The bar needs to be reduced by 102mm and the capping and covers need to be cut to match. Using D609 as an example on a standard Victorian 525mm wall the resulting parts should now all be 1058mm in length.



6'		
Part No	mm	Quantity
D1073	1997	1
D1079	1897	1
D1082	N/A	2
D1089	N/A	4
BOLM6X16		8
NUTM6		8
EV0329	13	4
SYSCR2	50	8
SYRAWL	50	8

8'		
Part No	mm	Quantity
D1072	2617	1
D1078	2517	1
D1082	N/A	2
D1089	N/A	5
BOLM6X16		10
NUTM6		10
EV0329	13	4
SYSCR2	50	10
SYRAWL	50	10

10'		
Part No	mm	Quantity
D1071	3237	1
D1077	3137	1
D1082	N/A	2
D1089	N/A	6
BOLM6X16		12
NUTM6		12
EV0329	13	4
SYSCR2	50	12
SYRAWL	50	12

12'		
Part No	mm	Quantity
D1070	3857	1
D1076	3757	1
D1082	N/A	2
D1089	N/A	7
BOLM6X16		14
NUTM6		14
EV0329	13	4
SYSCR2	50	14
SYRAWL	50	14

It is intentional that your valley gutter e.g. D1073 is 100mm longer than its corresponding flange e.g. D1079. The valley gutter should protrude away from the flanges by 50mm at either end. This allows the valley gutter to extend beyond the frame minimising any chance of leaks.

On extended buildings the valley flange/s and valley gutter/s will continue to be stepped away from each other to add strength, minimise leaks and to make sure that the valley gutter always extends by 50mm at each end of the building, see page 10. The valley gutter end caps 'D1082' will attach to this 50mm protrusion.

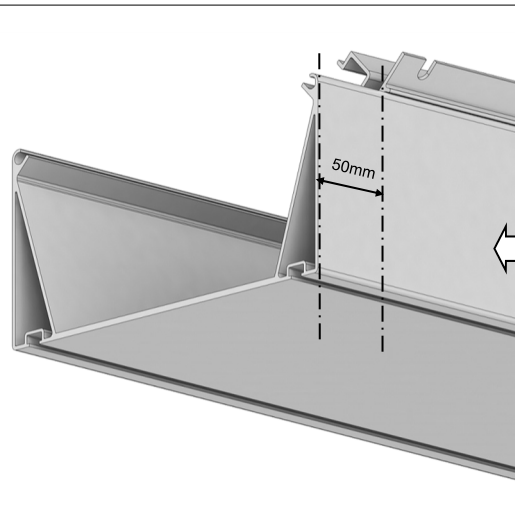
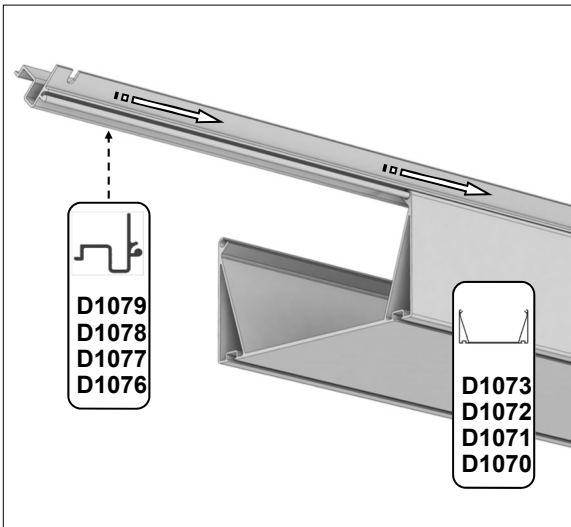
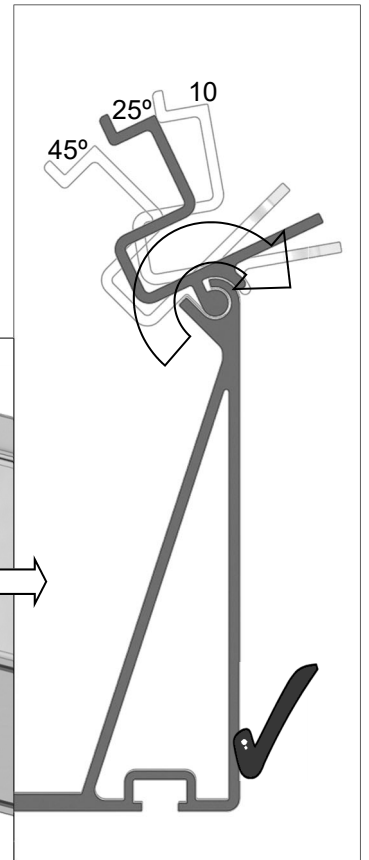

One 16mm bolt needs to be slid into each of the valley gutter bolt channels (see right) to enable each support castings D1089 to attach.

Position the castings roughly 100mm from the valley ends and also inline with each roof bar (see below and next page).

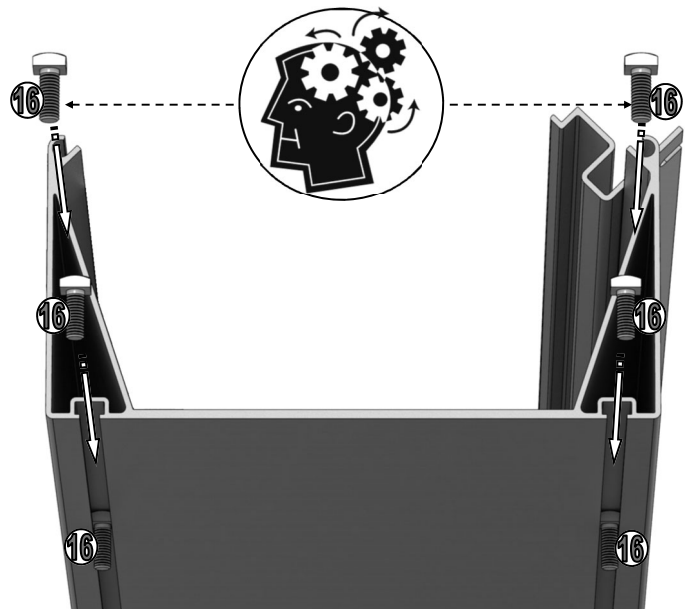

Insert the valley end caps D1082 (see right) into either end of the valley gutter until they abut parts D1122 (shown) and D1126.

The D1089 castings are used to secure the valley gutter to the wall using 2" (50mm) rawl plugs and screws. Ensure that everything is square and level especially the valley.



Silicone is used to seal between the wall and valley, it is important to create a good seal otherwise water can run down the wall into the building. You may want to consider putting some lead flashing between the wall and the valley especially if the adjoining wall is high or exposed. Take time to get this right, test for leaks with a watering can.

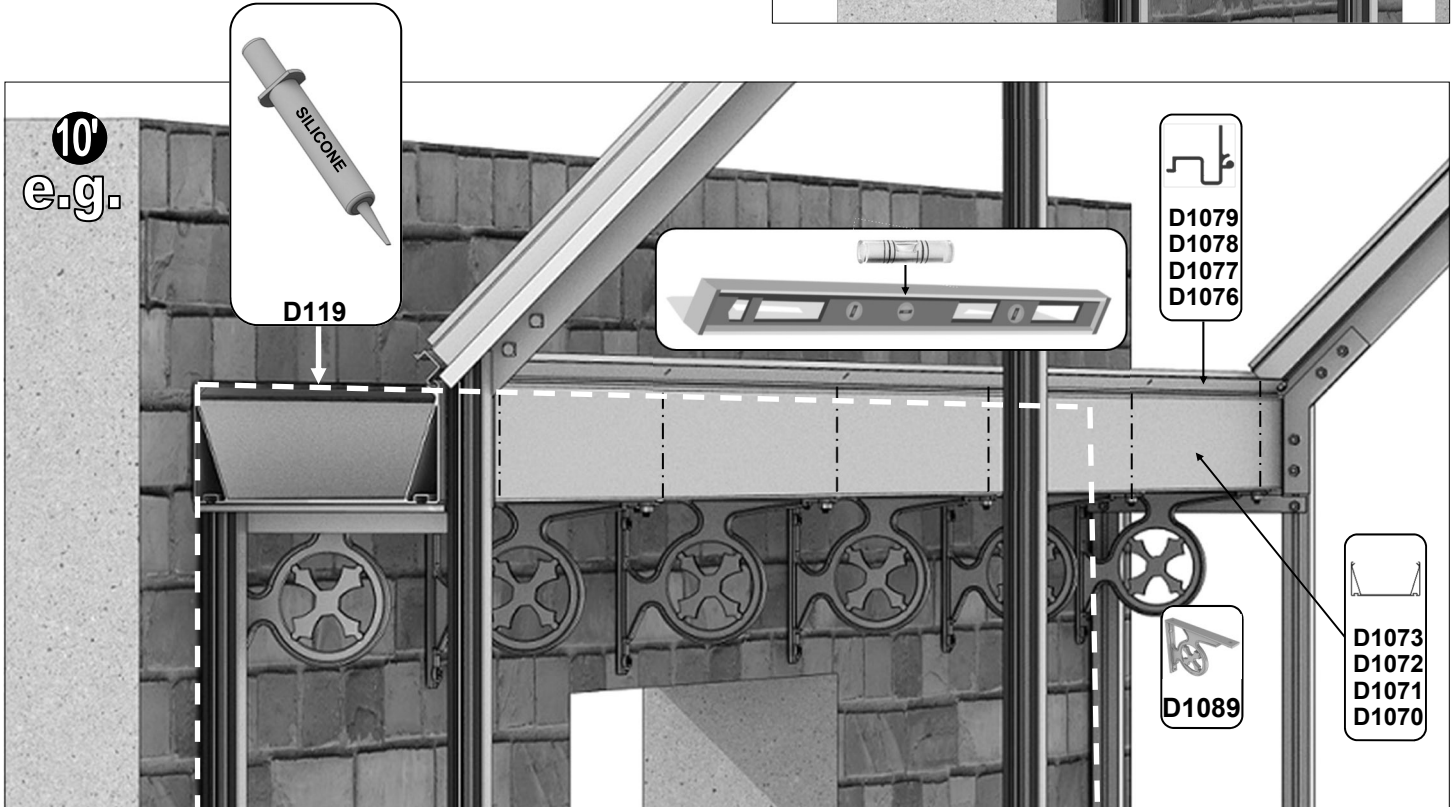
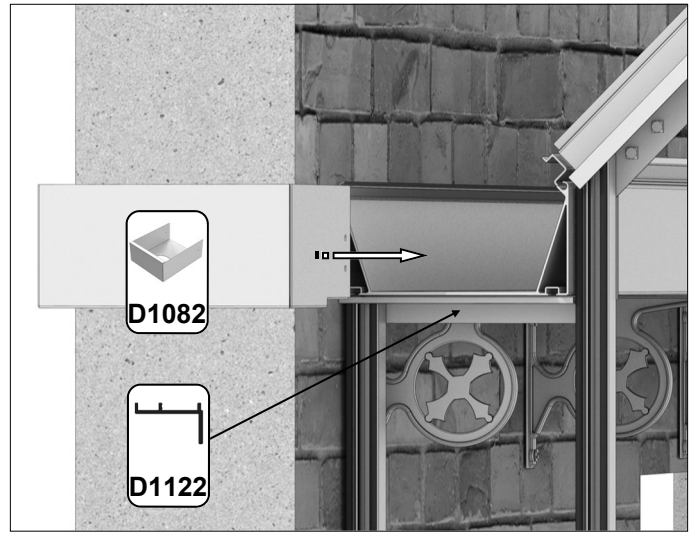

Self tapping EV0329 screws (see below) are used to secure the valley end caps D1082. You can add silicone to the D1082 end caps now or later when the valley downpipes are fitted.

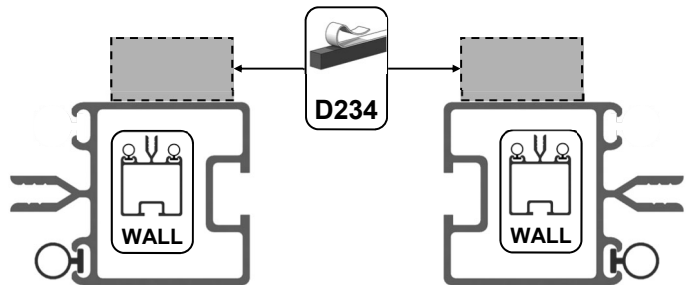
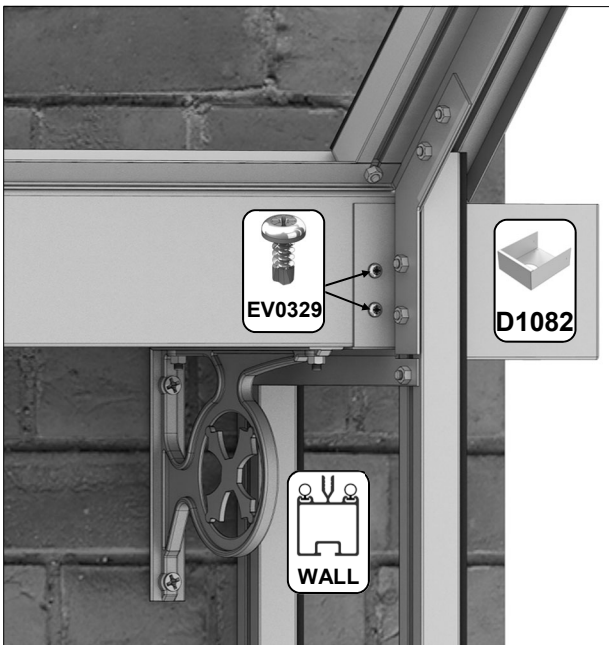

There are various methods for attaching your wall bars.

- 1) Drill through the vertical wall bars with a 7mm drill/hammer drill using a 7mm masonry bit, Use 3" screws (not supplied) to secure the wall bars.
- 2) Drill through the vertical wall bars with a 7mm drill bit and enlarge the inner hole to 10mm. Use 2" screws to secure the wall bars hiding the screw heads inside the bars to give a neat finish.
- 3) Use L-shaped brackets (D174) and 2" screws to secure the frame to the wall similar to anchoring the greenhouse down.

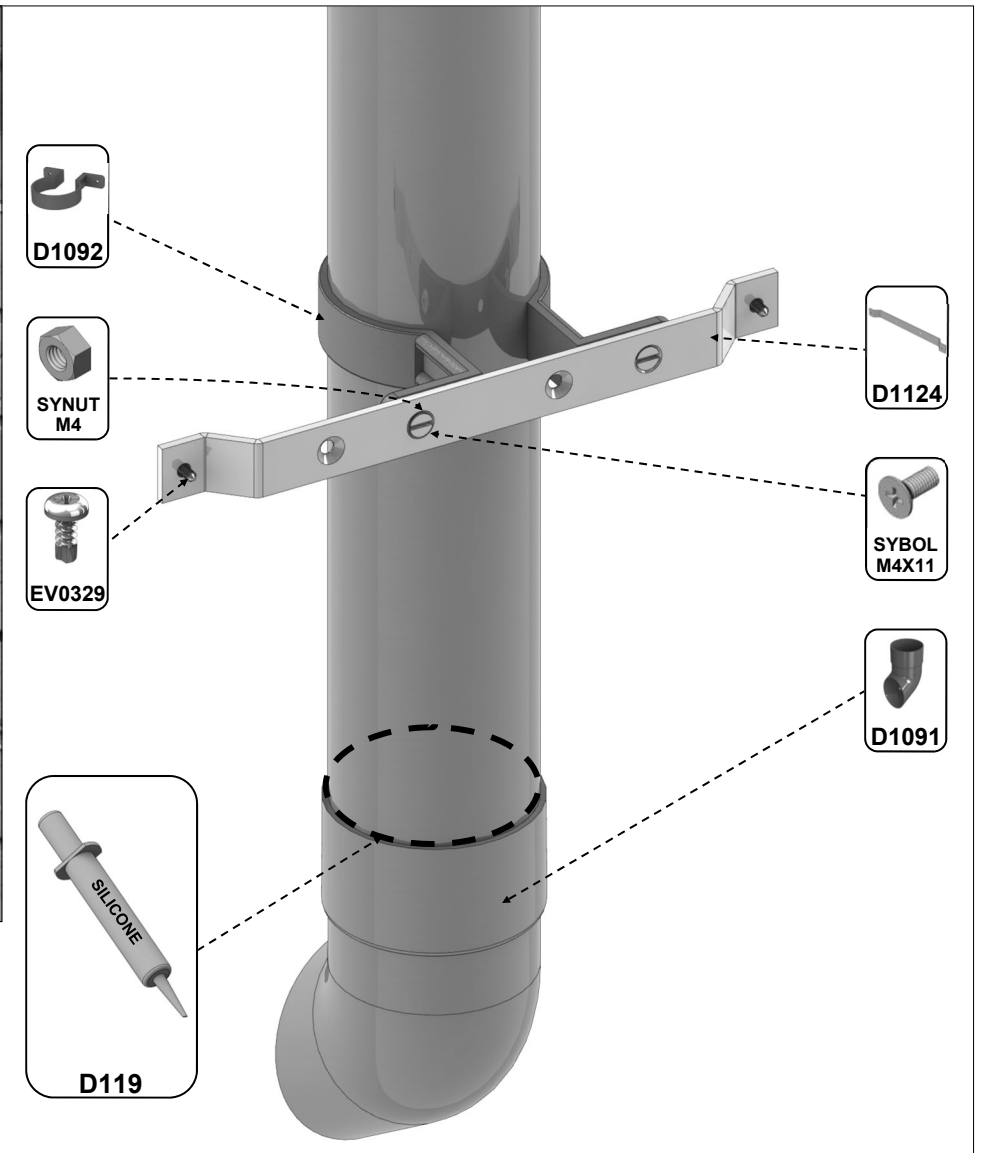
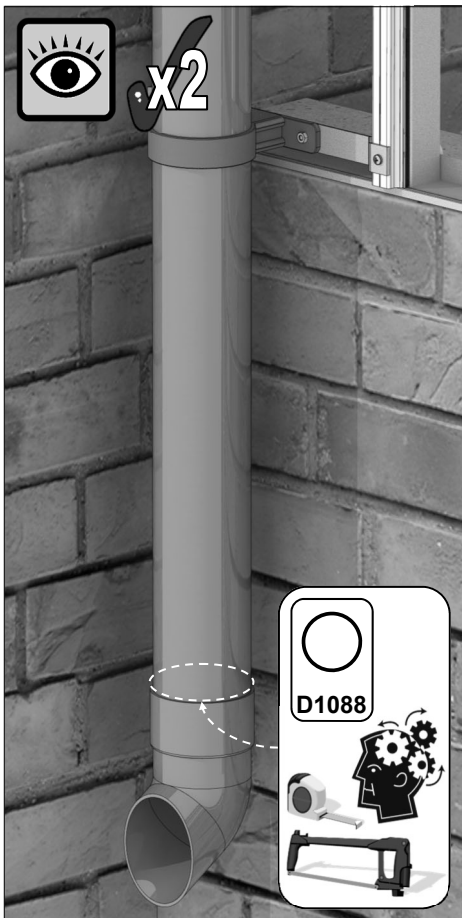
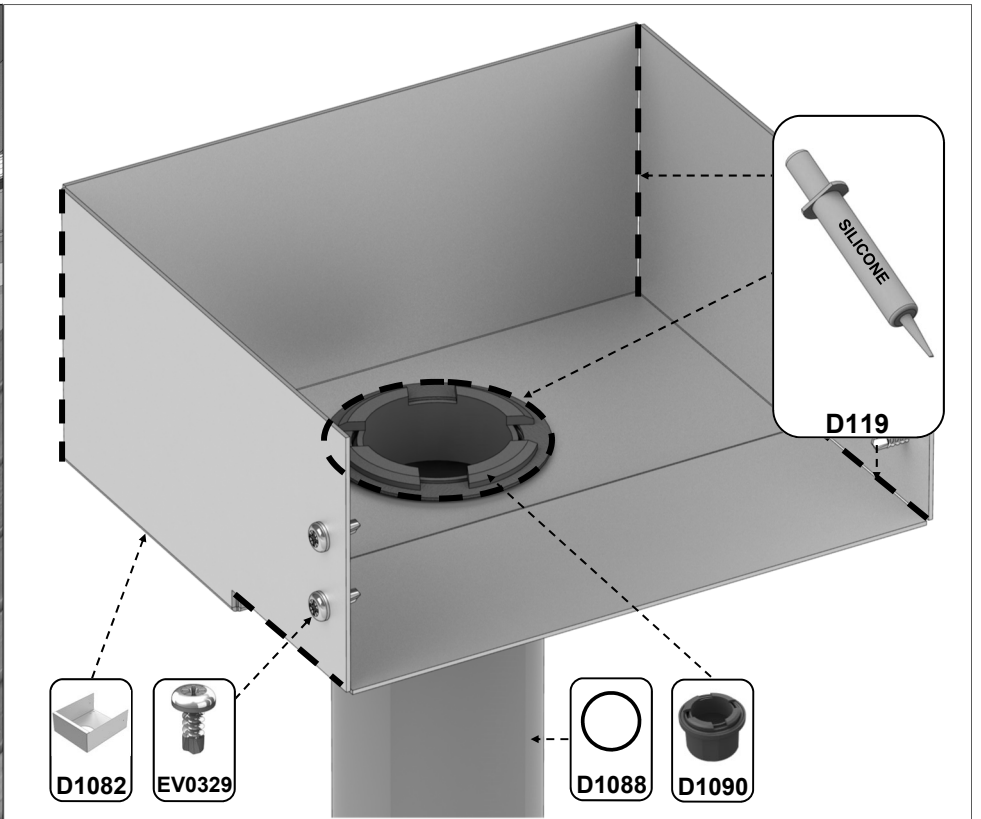

The tables below show all V-type valley related parts and their details for standard length and extended buildings.

QUANTITIES

Part No.	Section	Size (mm)	QUANTITIES							
			6'	8'	10'	12'	6' EX	8' EX		
D1070		3857				1				
D1071		3237			1					
D1072		2617		1						
D1073		1997	1							
D1074		2480							1	
D1083		1860					1			
D1076		3757				1				
D1077		3137			1					
D1078		2517		1						
D1079		1897	1							
D1080L		2480						1		
D1080R		2480						1		
D1084L		1860					1			
D1084R		1860					1			
D1085		214		2						
D1022		241		1						
D1026		241		1						
D1087		N/A						1		
D1089		N/A	4	5	6	7	3	4		

QUANTITIES

Part No.	Section	Size (mm)	QUANTITIES							
			6'	8'	10'	12'	6' EX	8' EX		
D114		N/A		2					1	
D174		N/A		4						
D1082		N/A		2						
D1088 PLASTIC		2000 PIPE		2						
D1090 PLASTIC		N/A		2						
D1091 PLASTIC		N/A		2						
D1092		N/A		2						
D1095		260		2						
D1097	GUTTER SEALANT	300ml		1					1	
D1098		206							1	
EV 0329		13		8					6	
M6x11 CROP		10							4	
FS6506 HEX 16mm		16	18	20	22	24	6	8		
FS6504 M6		M6	18	20	22	24	10	12		
SYBOL M4X10		10		4						
SYNUT M4		N/A		4						
SY SCR2		50	12	14	16	18	6	8		
SY RAWL		50	12	14	16	18	6	8		

Joining and sealing valley gutters at extensions

MULTI-SPAN IMAGES SHOWN RATHER THAN V-TYPE BUT THE PRINCIPLE IS THE SAME.

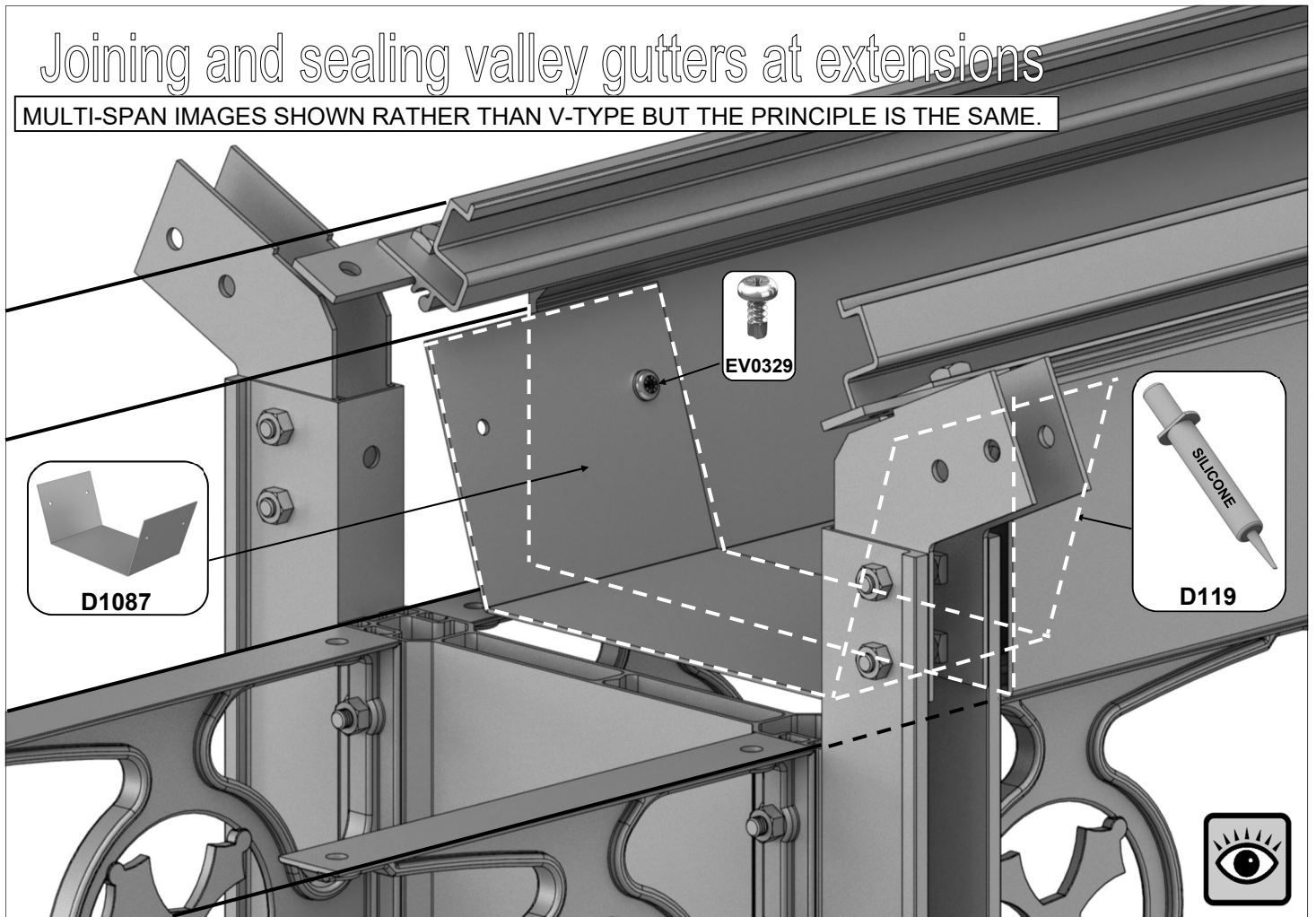

IMPORTANT: Please ensure that when fitting the extension seal plate 'D1098' that no one is stood in the gutter channel above until the 'D1089' spandrels have been reattached.

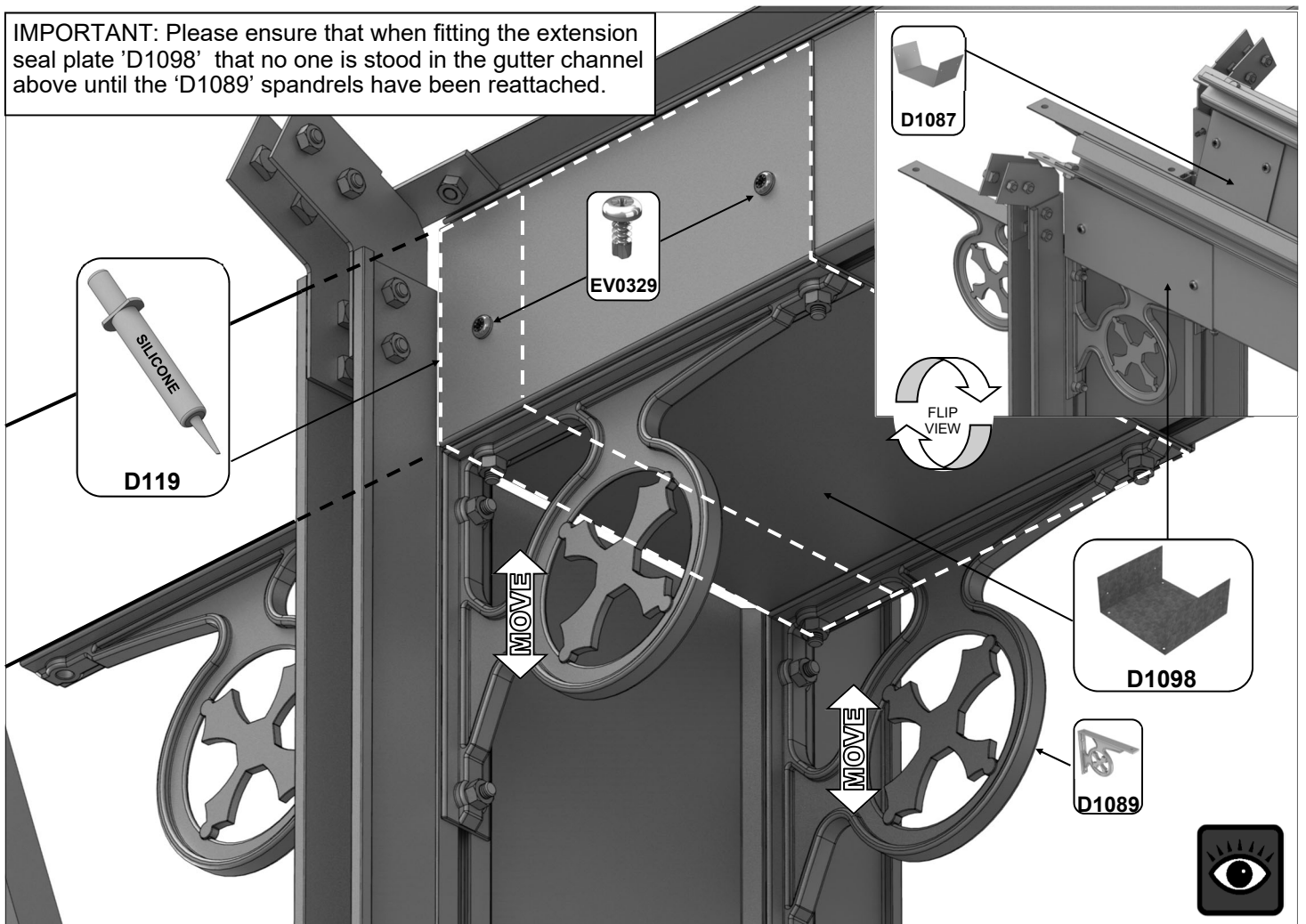

Please be aware that this is a multi-national manual, if you spot any errors or have any constructive comments regarding the manual please email james.spooner@greenhousepeople.co.uk and I will make the necessary amendments. Whilst the information contained in this booklet is accurate at the time of publication, changes in the course of Robinsons policy of improvement through development and design might not be indicated. We point out this fact to avoid any infringements of the Trade Descriptions Act and also to advise that Robinsons Greenhouses reserve the right to change specifications and materials without prior notice.

In addition any photographs of completed buildings would be most appreciated to add to our portfolio.



www.robinsonsgreenhouses.co.uk

To contact Robinsons Customer Services email us at sales@robinsonsgreenhouses.co.uk or call us on 01782 385 409.

Our address is Robinsons Greenhouses, Unit 19 Blythe Park, Cresswell, Stoke-on-Trent, Staffordshire, ST11 9RD